

Tactile Switches

6x6mm Right Angle SMT Tactile Switches with Tab

TP203C Series

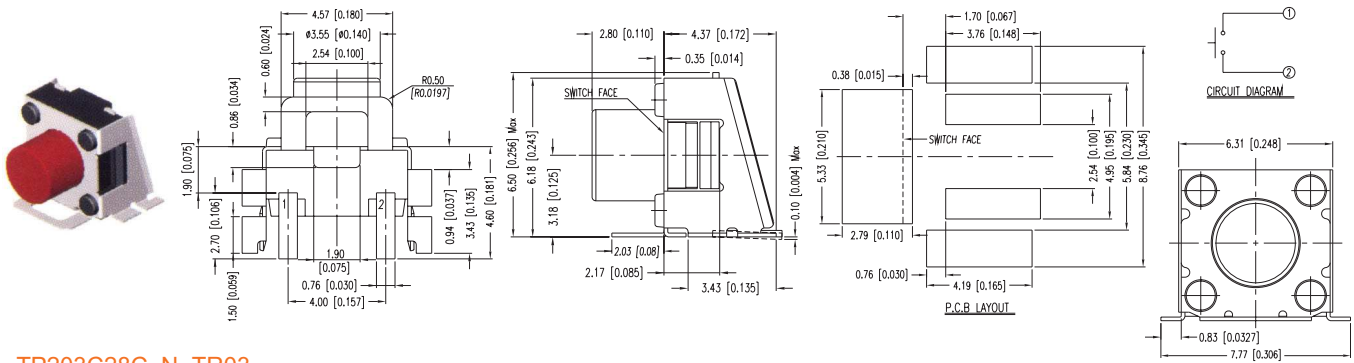

TP203C28C_N_TR03

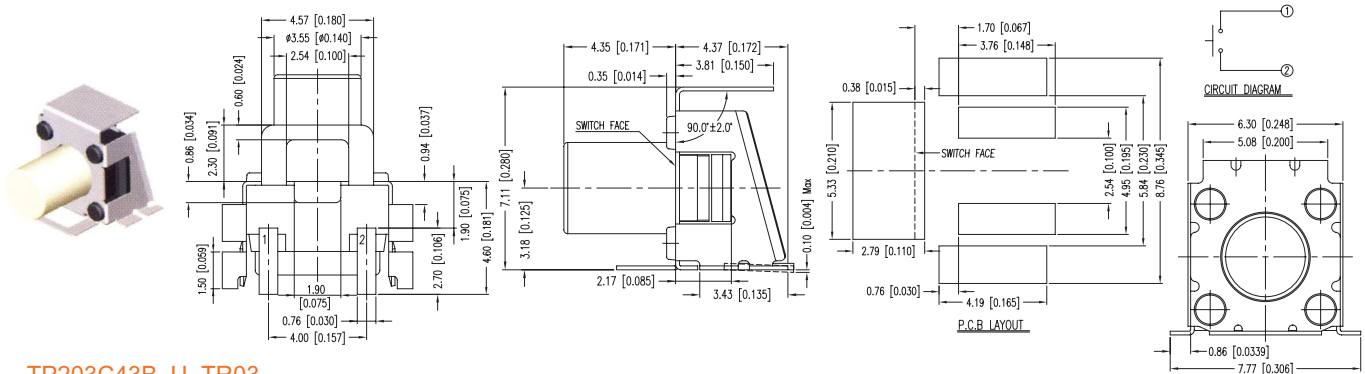

TP203C43B_U_TR03

How to order:

TP203C

1 HEIGHT OF ACTUATOR:

- 43 4.35mm
- 28 2.80mm
- 23 2.30mm
- 40 4.00mm
- 11 1.12mm

2 COLOR OF STEM:

- B White Stem
- C Red Stem
- H Gray Stem

3 OPERATING FORCE:

- 1 185±50gf
- 2 260±50gf

4 TAB:

- N Without Tab
- U Tab for auto-dipping

5 MATERIAL OF CONTACT & TERMINAL:

- GG Silver plated Contact, Silver plated Terminal

6 PACKAGE:

- TR Tape & Reel

7 ROHS:

- 03 RoHS & Lead Free Solderable

General Specifications:

MATERIALS

- » Cover: Stainless steel with silver plating
- » Contact: Stainless steel with silver or gold plating.
- » Terminal: Brass with silver or gold plating.
- » Stem: Nylon High-temp Thermoplastic UL94V-0
- » Seal: Silicone Rubber
- » Block: Nylon High-temp Thermoplastic UL94V-0 molded black
- » Base: LCP High-temp Thermoplastic molded black

MECHANICAL

- » Operation Force: 180±50gf(White);260±50gf(Red)
- » Stroke: 0.15mm Min.
- » Operation Temperature Range: -25°C to +70°C
- » Storage Temperature Range: -30°C to +80°C
- » Actuating Type: Tactile Feedback

ELECTRICAL

- » Electrical Life: 200,000 cycles
- » Rating: 1.5 mA 5VDC / 50mA 12/32 VDC
- » Contact Resistance: 100 mΩ max.
- » Insulation Resistance: 100M Ω min. at 500 VDC
- » Dielectric Strength: 250V AC / 1 minute

SOLDERING PROCESS

- » Hand Soldering: Use a soldering iron of 30 watts, controlled at 350°C approximately 5 seconds while applying solder.
- » Reflow Soldering: When applying reflow soldering, the peak temperature or the reflow over should be set to 260°C max

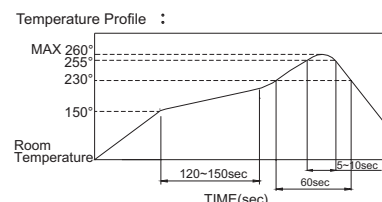

General Tolerance: +/-0.2mm